



**STRAUSS&CO.**  
Turning precision into value

**50**

years of precision

**NEEPIN**  **DENTAL**  
ΕΙΣΑΓΩΓΕΣ ΟΔΟΝΤΙΑΤΡΙΚΩΝ ΕΙΔΩΝ

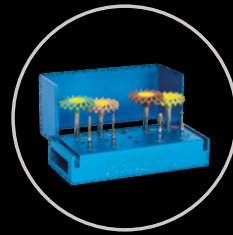
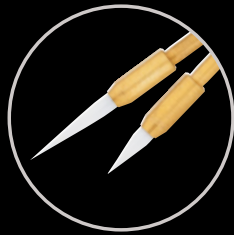



# Magic Strip

## Double-Sided Magic Strip

Strauss' double-sided Magic Strips excel at contouring and finishing Composite restorations and are especially well suited for Interproximal reductions.



Watch demo video

Code	MS-DS-RFL/SF	MS-DS-RFL/F	MS-DS-RFL/M	MS-DS-RFL/C
Description	Magic Strip refill kit - 10 strips + 2 handles - super fine grit size - double sided	Magic Strip refill kit - 10 strips + 2 handles - fine grit size - double sided	Magic Strip refill kit - 10 strips + 2 handles - medium grit size - double sided	Magic Strip refill kit - 10 strips + 2 handles - coarse grit size - double sided
Thickness (mm)	0.1	0.15	0.23	0.32
Code	MS-DS-RFL-5/SF	MS-DS-RFL-5/F	MS-DS-RFL-5/M	MS-DS-RFL-5/C
Description	Magic Strip refill kit - 5 strips + 1 handle - super fine grit size - double sided	Magic Strip refill kit - 5 strips + 1 handle - fine grit size - double sided	Magic Strip refill kit - 5 strips + 1 handle - medium grit size - double sided	Magic Strip refill kit - 5 strips + 1 handle - coarse grit size - double sided

Code	MS-SAW-RFL
Description	Magic Strip refill kit - 10 strips + 2 handles - super fine grit size - single side
Thickness (mm)	0.05
Code	MS-SAW-RFL5
Description	Magic Strip refill kit - 5 strips + 1 handle - coarse grit size - double sided

## Single-Sided Magic Strip

Our versatile single-sided Magic Strips are perfect for contouring and finishing Composite restorations and for single tooth slenderization.

Code	MS-SS-RFL/SF	MS-SS-RFL/F	MS-SS-RFL/M	MS-SS-RFL/C
Description	Magic Strip refill kit - 10 strips + 2 handles - super fine grit size - single sided	Magic Strip refill kit - 10 strips + 2 handles - fine grit size - single sided	Magic Strip refill kit - 10 strips + 2 handles - medium grit size - single sided	Magic Strip refill kit - 10 strips + 2 handles - coarse grit size - single sided
Thickness (mm)	0.09	0.11	0.15	0.22
Code	MS-SS-RFL-5/SF	MS-SS-RFL-5/F	MS-SS-RFL-5/M	MS-SS-RFL-5/C
Description	Magic Strip refill kit - 5 strips + 1 handle - super fine grit size - single sided	Magic Strip refill kit - 5 strips + 1 handle - fine grit size - single sided	Magic Strip refill kit - 5 strips + 1 handle - medium grit size - single sided	Magic Strip refill kit - 5 strips + 1 handle - coarse grit size - single sided



Code	MS-DS-KIT	MS-INTRO-KIT	MS-SS-KIT
Description	Magic Strip kit - 10 strips + 2 handles - variety of grit sizes - double side	Magic Strip kit - 10 strips + 2 handles - variety of grit sizes - single + double side	Magic Strip kit - 10 strips + 2 handles - variety of grit sizes - single side





# FG Diamond Burs



Cat. No.	A0	A1	A2	A3	A4	A5
Code	801-009	801-012	801-014	801-018	801-022	801-032
ISO No.	001-009	001-012	001-014	001-018	001-022	001-032
Head Size	009	012	014	018	022	032
Head Length						
Total Length	19	19	19	19	19	19
S. Fine			▲	▲		
Fine			▲	▲		
Medium	▽		▽			▽
Coarse	▽	▽	▽	▽	▽	▽
S. Coarse						

**Round**



Cat. No.	A11
Code	802-012
ISO No.	002-012
Head Size	012
Head Length	2.5
Total Length	19
S. Fine	
Fine	
Medium	▽
Coarse	▽
S. Coarse	

**Round + Neck**



Cat. No.	A1L	A2L	A3L	A4L	A5L
Code	801L-012	801L-014	801L-018	801L-022	801L-032
ISO No.	001-012	001-014	001-018	001-022	001-032
Head Size	012	014	018	022	032
Head Length					
Total Length	24	24	24	24	24
S. Fine					
Fine					
Medium					
Coarse	▽	▽	▽	▽	▽
S. Coarse					

**Surgical Length Round**



Cat. No.	B0	B1	B2	B3	B4
Code	805-009	805-012	805-018	807-014	807-018
ISO No.	010-009	010-012	010-018	225-014	225-018
Head Size	009	012	018	014	018
Head Length	0.9	1.3	1.6	3	5
Total Length	19	19	19	19	19
S. Fine					
Fine					
Medium					
Coarse	▽	▽	▽	▽	▽
S. Coarse					

**Inverted Cone**



Cat. No.	M5	M1	M6	M2
Code	806-014	813-016	806-016S	813-018
ISO No.	032-014	032-016	032-016	032-018
Head Size	014	016	016	018
Head Length	2	1.3	2.5	2.1
Total Length	19	16	19	17
S. Fine				
Fine				
Medium				
Coarse	▽	▽	▽	▽
S. Coarse				

**Double Inverted Cone**



Cat. No.	M4
Code	811-033
ISO No.	038-033
Head Size	033
Head Length	5.5
Total Length	21
S. Fine	
Fine	
Medium	▽
Coarse	▽
S. Coarse	

**Barrel**



Cat. No.	G4	G5
Code	909-048	909-054
ISO No.	067-048	068-054
Head Size	048	054
Head Length	1	2.3
Total Length	15	19
S. Fine		
Fine		
Medium	▽	▽
Coarse		
S. Coarse		

**Round Wheel**



# FG Diamond Burs



Cat. No.	G1	G2	G3
Code	818-030	818-040	818-050
ISO No.	042-030	041-040	041-050
Head Size	030	040	050
Head Length	0.8	0.7	0.7
Total Length	19	19	19
S. Fine			
Fine			
Medium	▽		▽
Coarse		▽	
S. Coarse			

Wheel



Cat. No.	BR2	BR3	BR4
Code	651-016	654-016	655-018
ISO No.	511-016	517-016	519-018
Head Size	016	016	018
Head Length	6	6	8
Total Length	17.5	18.5	20.5
S. Fine			
Fine			
Medium		▽	▽
Coarse	▽	▽	▽
S. Coarse			

Gross Reduction



Cat. No.	AB2	AB1
Code	830-014	830-016
ISO No.	237-014	237-016
Head Size	014	016
Head Length	2.5	2.5
Total Length	17	19
S. Fine		
Fine		
Medium		
Coarse	▽	▽
S. Coarse		

Pear



Cat. No.	K1	K11	K2	K2R
Code	368-016	368-018	368-023	379-023
ISO No.	257-016	257-018	257-023	277-023
Head Size	016	018	023	023
Head Length	3.3	4.5	5.3	4.4
Total Length	20	18.5	20	19
S. Fine	▽		▽	
Fine	▽		▽	
Medium				
Coarse	▽	▽	▽	▽
S. Coarse				

Egg/Football



Cat. No.	D0	D1	D2	D3	D12	D4
Code	835-008	835-010	835-016	836-012	837-010	837-014
ISO No.	109-008	109-010	109-016	110-012	111-010	111-014
Head Size	008	010	016	012	010	014
Head Length	4	4	4	5.6	8	8
Total Length	19	19	19	21	21.5	21
S. Fine						
Fine						
Medium	▽		▽			
Coarse	▽	▽	▽	▽	▽	▽
S. Coarse						

Flat End Cylinder



Cat. No.	D4R
Code	881-014
ISO No.	141-014
Head Size	014
Head Length	8
Total Length	21
S. Fine	
Fine	
Medium	
Coarse	▽
S. Coarse	

Round End Cylinder



Cat. No.	F3	Z3	F02	F11	F05	F06	F07	F1	F2
Code	845-022	846-018	847-010	847-018	848-010	848-012	848-014	848-016	848-018
ISO No.	169-022	171-018	172-010	172-018	173-010	173-012	173-014	173-016	173-018
Head Size	022	018	010	018	010	012	014	016	018
Head Length	2.5	7	8	8.5	10	10	10	10	10
Total Length	16	19.5	21.5	21	23	23	24	22.5	22.5
S. Fine									
Fine									
Medium	▽	▽				▽	▽		
Coarse	▽	▽	▽	▽	▽	▽	▽	▽	▽
S. Coarse									

Flat End Taper



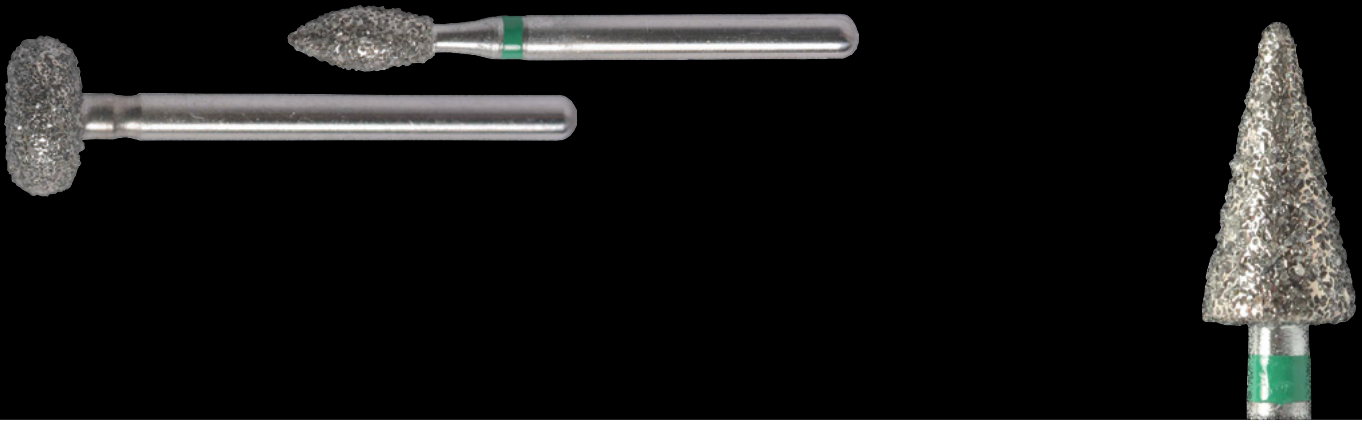



# FG Diamond Burs



Cat. No.	C1	C2	C3	C11	M3	F1R	F2R	C4
Code	855-014	855-018	855-025	856-012	856L-018	850-016	850-018	850-021
ISO No.	197-014	197-018	197-025	198-012	198-018	199-016	199-018	199-021
Head Size	014	018	025	012	018	016	018	021
Head Length	6.3	7	7	8	9	10	10	10
Total Length	21	19	21	21	21	22.5	22.5	22
S. Fine								
Fine								
Medium	▽			▽				
Coarse	▽	▽	▽	▽	▽	▽	▽	▽
S. Coarse						▽		



**Round End Taper**



Cat. No.	K3
Code	825-038
ISO No.	164-038
Head Size	038
Head Length	7
Total Length	21
S. Fine	
Fine	
Medium	
Coarse	▽
S. Coarse	



**X-Mas Tree**



Cat. No.	E1	Z12	E12	E2	Z4	E11	Z11	E31	E32	E3	Z1	Z2
Code	852-012	858-010	858-012	858-014	858-015	859-010	859-012	859-014	859-016	859L-016	859-017	859-018
ISO No.	164-012	165-010	165-012	165-014	165-015	166-010	166-012	166-014	166-016	167-016	166-017	166-018
Head Size	012	010	012	014	015	010	012	014	016	016	017	018
Head Length	5.6	8	8	8	8	10	10	10	10	10.5	10	10
Total Length	19	22	22	21	20.5	23.5	22.5	23	23	23.5	22.5	22.5
S. Fine	▽	▽	▽	▽		▽				▽		
Fine				▽						▽		
Medium												
Coarse	▽	▽	▽	▽	▽	▽	▽	▽	▽	▽	▽	▽
S. Coarse												



**Needle**



Cat. No.	E4	E8	Z5	E5	E9	E6
Code	860-013	861-014	862-013	862-014	863-023	863-016
ISO No.	247-013	248-014	249-013	249-014	249-023	250-016
Head Size	013	014	013	014	023	016
Head Length	5.2	6	8	8	9	9.5
Total Length	19	20	20	21	21	22
S. Fine				▽	▽	▽
Fine				▽	▽	▽
Medium	▽			▽	▽	▽
Coarse	▽	▽	▽	▽	▽	▽
S. Coarse						



**Flame**



Cat. No.	S11	PR1
Code	879-012	879-012
ISO No.	289-012	290-012
Head Size	012	012
Head Length	8	10
Total Length	22	23.5
S. Fine		
Fine		
Medium	▽	
Coarse	▽	▽
S. Coarse		



**Torpedo Cylinder**



# FG Diamond Burs



Cat. No.	S4	T5	T4	S2	S5	T3	T1	T2	S3	S1	T6
Code	877K-014	877K-016	877K-018	878K-014	878K-016	878K-018	878K-020	878K-022	879K-014	879K-016	879K-018
ISO No.	297-014	297-016	297-018	298-014	298-016	298-018	298-020	298-022	299-014	299-016	299-018
Head Size	014	016	018	014	016	018	020	022	014	016	018
Head Length	6.5	6.5	6.5	8	8	8	8	8	9.5	9.5	9.5
Total Length	19	18.5	19	21	20.5	20	20.5	20.5	22	22	22
S. Fine											
Fine											
Medium	▽		▽	▽	▽	▽			▽		
Coarse	▽	▽	▽	▽	▽	▽	▽	▽	▽	▽	▽
S. Coarse											

**Gingival Curettage**



Cat. No.	E71	E7	PR3
Code	885-010	885-012	879-014
ISO No.	130-010	130-012	131-014
Head Size	010	012	014
Head Length	8	8	10
Total Length	21.5	21	23
S. Fine			
Fine			
Medium		▽	
Coarse	▽	▽	▽
S. Coarse			

**Pointed Cylinder**



Cat. No.	E3R
Code	889-008
ISO No.	169-008
Head Size	008
Head Length	3
Total Length	24
S. Fine	
Fine	
Medium	
Coarse	▽
S. Coarse	

**Separation**



Cat. No.	PR12
Code	834-019
ISO No.	552-019
Head Size	019
Head Length	1X3
Total Length	20
For Depth (mm)	0.5
Fine	
Medium	▽
Coarse	
S. Coarse	

**Depth Cutting**



Cat. No.	L1
Code	851-019
ISO No.	220-019
Head Size	019
Head Length	10.2
Total Length	22
S. Fine	
Fine	
Medium	▽
Coarse	
S. Coarse	

**Safe End**



Cat. No.	K2SP	C3SP	M31SP	E5SP	E6SP
Code	T368-023	T855-025	T856-016	T862-014	T863-016
ISO No.	T257-023	T197-025	T198-016	T249-014	T249-016
Head Size	023	025	016	014	016
Head Length	5.3	7	8	8	9.5
Total Length	20	21	21	21	22
Medium	▽	▽	▽	▽	▽

**Specials - Cool Cut**



# 6 Blades Operative & Surgical

Cat. No.	2	3	4	5	6	7	8
Head Size	010	012	014	016	018	021	023
Head Length	0.8	1	1.1	1.2	1.5	1.9	1.9
RAOS					*		*
HP	*	*	*	*	*	*	*

**Round**

Cat. No.	1556
Head Size	009
Head Length	4.1
FG	*

**Round End Cross Cut Fissure**

Cat. No.	1702
Head Size	016
Head Length	4.1
FGOS	*

**Round End Cross Cut Tapered Fissure**

Cat. No.	171L
Head Size	017
Head Length	5.7
FG	*

**Long Tapered Fissure**

Cat. No.	559	560
Head Size	014	016
Head Length	4.5	4.5
HP	*	*

**Cross Cut Fissure**

Cat. No.	702	703
Head Size	016	021
Head Length	4.5	5
HP	*	*

**Cross Cut Tapered Fissure**

Cat. No.	B1557	B1558
Head Size	010	012
Head Length	4.1	4.1
FG	*	*

**Round End Cross Cut Fissure**

Cat. No.	B330	B331
Head Size	008	010
Head Length	2	2
FG	*	*

**Pear**

Cat. No.	FG-K2R	FG-F03	FG-C12
Description	Football	Flat end taper	Round end taper
Head Length	4.5	8	8
Head Size	023	012	014

## Zekrya

Cat. No.	Zekrya23	Zekrya28
Head Size	016	016
Head Length	11	11
Total Length	23	28
FG	*	*

## Endo Access

Cat. No.	EndoZ
Head Size	016
Head Length	9
Total Length	23
FG	*

## Lindemann

Cat. No.	Lindemann161	Lindemann162
Head Size	016	016
Head Length	10	10
Total Length	25	25
FG	*	*
RA	*	*
Blade Geometry	Plain Cut	Cross Cut



## Shine 1-2 Composite Finishing Kit

An aesthetics restoration finishing method – morphological quality & fast restoration designed by Dr. Matan Avital. This set is designed to make the tough task of Composite finishing significantly simpler, shorter and more efficient while giving excellent clinical results. This set will enable the dentist to polish the Composite without the need to use disc, paste or polisher.

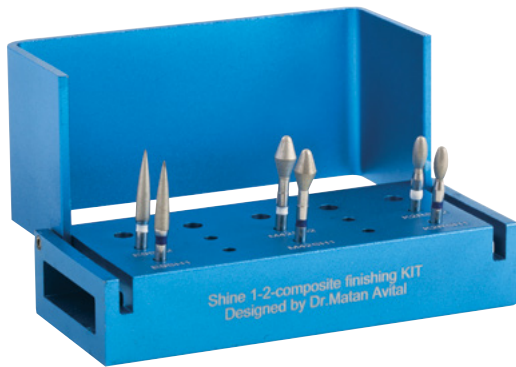

CAT#: SH12SET

Profile	Cat. No.	Application
	E9SH1	Buccal, cervical & inter-proximal Composite finishing step 1
	K2RSH1	Palatal Composite finishing step 1
	M42SH1	Occlusal Composite finishing step 1
	E9SH2	Buccal, cervical & inter-proximal Composite finishing step 2
	K2RSH2	Palatal Composite finishing step 2
	M42SH2	Occlusal Composite finishing step 2

## Composite Finishing Kit

The most popular Composite finishing kit contains super fine and extra-extra fine burs.



CAT#: COMSET1

Profile	Cat. No.	Application
	A4SF	Fine finishing and polishing of the marginal ridge.
	E4SF	Fine finishing and polishing of Composite excess restoration margins.
	E5SF	Fine finishing and polishing of Composite restoration margins.
	K2SF	Fine polishing of Palatal/lingual surface.
	PR2SF	Fine finishing of the Occlusal surface.
	T5SF	Fine finishing of Composite excess at margins
	A3XXF	Very fine polishing of the marginal ridge.
	A4XXF	Very fine polishing of the marginal ridge.
	E4XXF	Very fine polishing of Composite excess at margins.
	E5XXF	Very fine polishing of Composite excess at margins.
	K2XXF	Very fine polishing of palatal/lingual surface.
	PR2XXF	Very fine polishing of the occlusal surface.



## Magic Touch Basic Kit

A basic set for ceramic bite adjustments.



CAT#: MagicT1

Profile	Cat. No.	Application
	A3PF	Magic Touch - adjustments / endo access
	A4PF	Magic Touch - adjustments / endo access
	E5PF	Magic Touch - adjustments / crown cutting
	E7PF	Magic Touch - adjustments / crown cutting
	K2PF	Magic Touch - adjustments
	PR15PF	Magic Touch - adjustments / detailing
	PR2PF	Magic Touch - adjustments
	T2PF	Magic Touch - adjustments

## Mini Magic Touch Kit

Introductory kit for the Magic Touch line.

Profile	Cat. No.
	M3PF
	A4PF
	K2RPF
	T2PF



CAT#: MiniMagicT1

## Magic Touch Cerec Kit

A complete set for Cerec restoration E-MAX® and Zirconia adjustments.



CAT#: Cereckit1

Profile	Cat. No.	Application
	A3PF	Magic Touch - adjustments / endo access
	E5PF	Magic Touch - adjustments / crown cutting
	K2RPF	Magic Touch - adjustments
	M3PF	Magic Touch - adjustments / crown cutting
	RDRAZ14M	Zirconia smoothing polisher
	RDRAZ14F	Zirconia polishing polisher
	RDRAE14M	Lithium Disilicate smoothing polisher
	RDRAE14F	Lithium Disilicate polishing polisher





## Crown Lengthening Kit

The new Crown Lengthening kit is designed to be used in an orderly sequence and guide the clinician to achieve the desired outcome precisely, predictably and safely. It includes special custom made burs with laser depth markings. Designed by Prof. Nitzan Bichacho and Dr. Cobi Landsberg.



CAT #: PERIOKIT1

Profile	Cat. No.	Application
	A4LC	Round Diamond bur
	A3LC	Round Diamond bur
	MR10L2M	Side cutting Diamond bur (narrow)
	MR10L3M	Side cutting Diamond bur (narrow)
	FG957	End cutting Carbide bur
	MR015LM	End cutting Diamond bur
	MR010LM	End cutting Diamond bur
	C2411S/M	Tapered side cutting Diamond bur
	C2411S/XXF	Tapered side cutting Diamond bur
	C244/XXF	Tapered final polishing Diamond bur

## Extra Long Surgical Kit

Round extra long burs for surgical use.

Profile	Cat. No.
	A2XLM
	A3XLM
	A4XLM



CAT #: AXL-KIT-M

## Flat End Taper

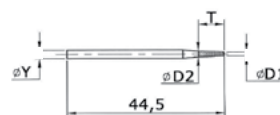

Profile	Cat. No.	D1	D2	T
	h27	2.5	3.3	9.4

## Tissue Trimming

- Designed for soft-tissue surgery. The ceramic soft tissue trimmer bur is a rotary instrument that can be used as an alternative to using scalpel, electro-surgery and surgical blades.
- Using the tissue trimmer provides minimum bleeding.
- The biocompatible hard oxide points are made to cut tissue without burning.

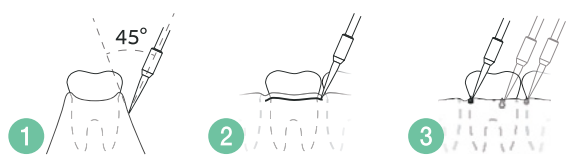

Cat. No.	FG-CER	FG-CEROS
Head Size	015	015
Head Length	5	8
Total Length	22.5	25
FG	✳	✳
<b>Tissue Trimmer</b>		





# Degranulation Kit



CAT #: GRKIT1

Cat. No.	Strauss G 1 mm	Strauss G 2.5 mm	Strauss G 3.0 mm	Strauss G 3.5 mm
Head Size	1 mm	2.5 mm	3.0 mm	3.5 mm
Head Length	31 mm	31 mm	31 mm	31 mm

# Safe Sinus Lift Kit



CAT #: SINKIT2

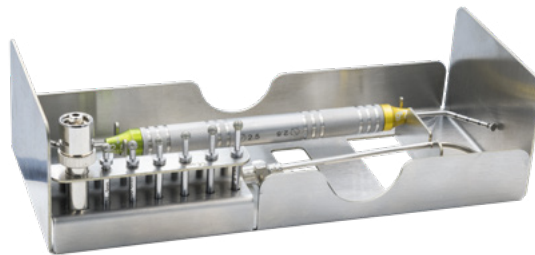

CAT #: SINKIT3



CAT #: SINKIT5

Item	Box Type	3+4 mm Burs	5-8 mm Burs	9-10 mm Burs	Suction	Currete - 2.5/2.8 mm	Currete - 3.5/4 mm
Sinkit2	Bur Block		*	*			
Sinkit3	Tray		*	*	*	*	
Sinkit5	Bur Block	*	*				
SinkitPRO1	Tray	*	*	*	*	*	*



19 Hayezira St. Industrial Area, P.O.Box 2521,  
Raanana 4366363 Israel  
Tel: 972-9-7461631 | Fax: 972-9-7461636  
Email: info@strauss-co.com



Φωκίδος 51, Αθήνα 11527  
T. 210 7711605 F. 210 7754065  
e-mail: info@negrin.gr  
http://www.negrin.gr

